

Applications of Time-Resolved Resonance Raman Spectroscopy in Environmental Chemistry

Philip J. Reid, University of Washington

Introduction

Ultrafast vibrational spectroscopic techniques (i.e., picosecond and femtosecond infrared absorption and time-resolved resonance Raman (TRRR) spectroscopy) have proven to be extremely versatile in their ability to elucidate the dynamical aspects of many photochemical processes.^{1,2} Recent advances in solid-state lasers have resulted in the commercial availability of high-repetition rate, high-energy sources that hold the promise of extending the applicability and versatility of these spectroscopic techniques. Over the past few years, we have incorporated many of these advances in our TRRR investigations of environmental photochemistry. In this article, we review our recent progress in elucidating the condensed-phase reaction dynamics of halooxides. This work has provided detailed insight into the photochemical reactivity of these environmentally important molecules.

Experimental

In TRRR spectroscopy, an actinic or "pump" pulse initiates the photochemistry of interest and the scattering from a second, temporally delayed "probe" pulse is monitored. The temporal evolution in scattered intensity provides a measure of the photoproduct-formation kinetics, with simultaneous evolution of the vibrational spectrum providing definitive assignment of the photoproducts that are formed. In theory, TRRR is an extremely powerful technique; however, its application has been relatively limited due to the complexity of ultrafast laser systems needed to perform these studies. In addition, the necessity of resonant actinic and probe beams places severe demands on the frequency agility of the spectrometer. Recent developments in Ti:Sapphire laser technology have resulted in the development of light sources that are of high energy (~mJ/pulse), high repetition rate (1-5 kHz) and tunable using a variety of non-linear optical techniques.^{3,4} The spectrometer used in our TRRR work (Figure 1) provides an excellent example of how Ti:Sapphire technology has allowed for the development of extremely versatile TRRR spectrometers. The system begins with a small-frame, argon-ion laser that pumps a homebuilt Ti:Sapphire oscillator.⁵ The oscillator output is regeneratively amplified utilizing the chirp-pulse amplification technique employing Ti:Sapphire as the amplifier gain medium. One unique aspect of our amplifier is the use of birefringent tuning elements in the amplifier cavity resulting in the production of near-transform-limited pulses tunable between 300 fs and 1.5 ps with spectral coverage over the entire bandwidth of the 30-fs seed pulse (~60 nm centered at 800 nm). This feature allows the user to match the spectral resolution of the laser to perform a particular experiment. Amplified pulse energies of 1 mJ at a repetition rate of 1 kHz are produced representing a factor of 20 improvement in repetition rate relative to previous TRRR spectrometers of comparable pulse energy.² Through harmonic generation of the amplified output, photolysis and probe wavelengths down to ~200 nm with pulse energies as high as 4 μJ at this probe wavelength are available. In addition, it has been demonstrated that optical parametric amplification can be used to generate actinic and probe light throughout the visible and near-UV; however, the time-bandwidth product of these pulses is typically larger than the transform limit.^{3,4} In short, the high repetition rate, frequency agility, and inherent stability of Ti:Sapphire based TRRR

Continued on page 3

From the Executive Director

D. C. Neckers, Executive Director, Center for Photochemical Sciences, Bowling Green State University

As a graduate student in the 1960s, I was required to take courses in a so-called minor subject area...physics, mathematics, biochemistry, pharmacy, etc. Like most others in my research group I chose math. One of the math courses that seemed hidden in the catalog was a course in computer programming. Several organic chemists signed up to take it. This was 1962.

We programmed in "machine language", add to the lower, move to the upper, do something else to the distributor. There were codes for all of these actions, and we had to keypunch cards using a cumbersome machine that marginally resembled a typewriter. Since the key strokes were completely different from a normal typewriter, this was almost more trouble than it was worth. Anyone who could type was actually penalized because one was forever making keystroke errors just because one assumed "a" was at left pinky; in fact it was the right index.

After we assembled a collection of cards to form a program, we got a few seconds of machine time to see if the program ran. Most of the time it did not, and we had to go on one of those interminable searches for the card with the keystroke "a" replaced by a "j", a "u" or an "n". Eventually, all the cards were corrected and we could try it again. If the program ran, the end result was often a very rapid way to add $1 + 1 + 1 \dots$.

For an impatient organic chemist, this seemed liked nonsense. But I had to have at least two mathematicians on my Ph.D. studies committee so I asked the Chair (and only faculty member) in computer programming in the math department to be one of them. The only question he asked in my final oral was "Do you see any use for computers in your research?".

My answer: "Not until they become smart enough to do something I need done, and smart enough to effortlessly teach me how to do it."

Well guess what? It took about 15 years but by the mid to late 1970s computers finally were smart enough to teach even hard-headed organic chemists how to use them. By the early 1980s many of us were wedded to desktop boxes. Soon the Macintosh and the mouse came along, and the effortlessness I had asked for became part of the equation.

I was on a committee with Nick Negroponte at the time. Before dinner Nick would go to his hotel room, plug in, and run the MIT Media Lab from a laptop he carried around. Nick was wired several years before the rest of us could find portable Macintoshes. Bowling Green didn't have a bitnet node until the early 1990s. But it got wired, and its getting more wired as we speak...to the tune of about \$41 mil's worth of cables and cords it calls its network.

Looking back, I don't regret that math requirement or that minor. I sometimes wonder what that computer programming teacher is doing now, and if he remembers that cocky young organic chemist who was sure no computer was ever going to be smart enough to teach him how to use it!

In This Issue

Applications of Time-Resolved Resonance Raman Spectroscopy in Environmental Chemistry	1
From the Executive Director	2
Imaging with Polymers, How It All Began	9
Carotenoids - Free Radical Interactions	12

Continued from page 1

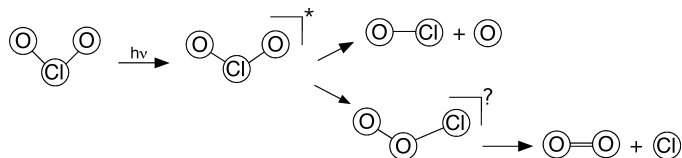
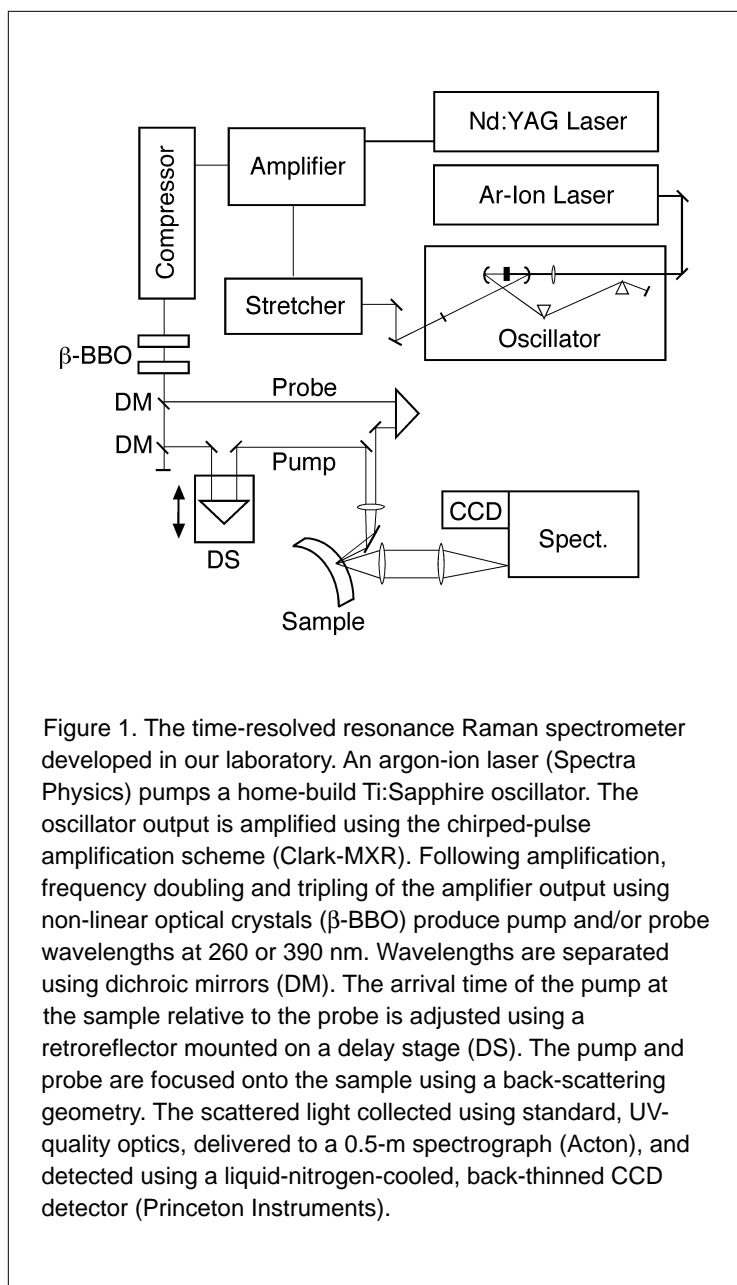

Scheme I. The general photochemical pathways available to OCIO following photoexcitation. In the scheme, "*" denotes electronically-excited OCIO, and "?" indicates that CIOO is a proposed intermediate.

spectrometers promises to increase the applicability of this spectroscopic technique. With respect to our work in environmental photochemistry, many of the compounds of interest have extremely modest absorption and resonance Raman cross sections. It is only through these recent developments in laser technology that the TRRR studies outlined below were possible.

Application to Environmental Chemistry: Chlorine Dioxide

Halogen-containing compounds (HCCs) are of central importance in environmental chemistry due to their ability to photochemically produce atomic halogens. Our initial studies have focused on the chemistry of halooxides, with chlorine dioxide (OCIO) serving as an excellent example of this reaction class. There has been much recent interest in OCIO due to its participation in a variety of stratospheric processes.⁶⁻¹¹ Following the photoexcitation of OCIO, two photochemical processes can occur: the production of ClO and O, or Cl and O₂ as illustrated in Scheme I. With regards to the Cl and O₂ channel, it has been suggested that these products are formed through the ground-state decomposition of CIOO produced via OCIO photoisomerization. Until recently, this species has only been observed in low-temperature matrixes.⁷ What is remarkable about this photochemistry is that the quantum yield for Cl production (Φ_{Cl}) is dependent on the environment in which the reaction occurs. For example, Φ_{Cl} is only ~ 0.04 in the gas phase, but increases to unity in low-temperature matrixes.⁷ The chemistry in solution is intermediate between these two limits with $\Phi_{\text{Cl}} = 0.1-0.2$ in water and methanol.¹²⁻¹⁸ Since the environmental impact of OCIO arises from its ability to produce Cl, understanding the origin of this phase-dependent reactivity is essential in order to model or predict the environmental impact of OCIO.

Recently, femtosecond transient-absorption studies of aqueous OCIO have attempted to define the photochemical dynamics of this compound in solution.¹²⁻¹⁹ Interestingly, three laboratories have performed transient-absorption studies of aqueous OCIO, and catholic agreement exists regarding both the kinetics and optical-density evolution that occurs following photoexcitation. However, the underlying reaction dynamics responsible for the optical-density evolution has been unclear. The transient-absorption data have been interpreted in terms

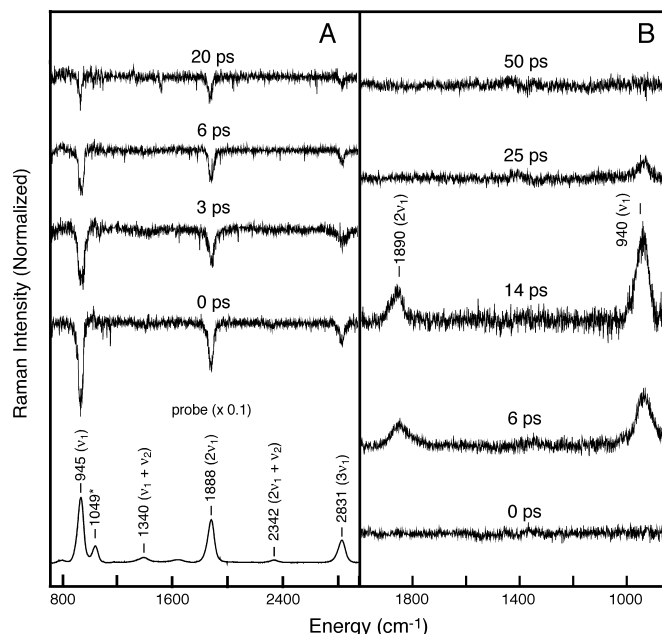

Figure 2. **A.** Time-resolved Stokes spectra for aqueous OCIO. Spectra were obtained with degenerate pump and probe wavelengths of 390 nm. The 0-ps Stokes spectrum demonstrates depletion in OCIO scattering due to photolysis. As the probe is delayed relative to the pump, the depletion amplitude decreases due to OCIO reformation via geminate recombination of the ClO and O photoproducts. The peak marked with an asterisk at 1049 cm^{-1} is due to NO_3^- added as an internal scattering standard. **B.** Time-resolved anti-Stokes spectra for aqueous OCIO. Spectra were obtained with degenerate pump and probe wavelengths of 390 nm. Intensity is observed for the fundamental and overtone transitions of OCIO consistent with excess vibrational energy being deposited along this coordinate following geminate recombination.

of both the appearance and vibrational relaxation of ClOO, or of ground-state OCIO formed by geminate recombination of the primary ClO and O photoproducts. Differentiation between these models is dependent on obtaining definitive spectroscopic evidence for the production of ClOO and/or the reformation of OCIO, a task ideally suited to TRRR spectroscopy.

The results of our initial TRRR studies of aqueous OCIO are presented in Figure 2A.^{19,20} In these experiments, TRRR spectra were obtained using degenerate pump and probe wavelengths at 390 nm, resonant with the ${}^2B_1\text{-}{}^2A_2$ electronic transition of aqueous OCIO. The time-dependent Stokes spectra shown in Figure 2A are “difference spectra” representing the difference between the scattered intensities in the presence of photolysis versus that when no photolysis occurs. At 0-ps delay (when the pump and probe beams are overlapped in time), the difference spectrum demonstrates large, negative intensity for transitions corresponding to ground-state OCIO. The observation of negative OCIO intensity is consistent with photoinduced depletion of the ground state. As the delay between the pump and probe is increased, the amplitude of the negative OCIO intensity decreases. By 20-ps delay, the OCIO depletion intensity is $\sim 20\%$ of that observed at 0-ps delay, and remains constant out to the longest delays investigated (500 ps). The decrease in OCIO depletion intensity as a function of delay immediately demonstrates that ground-state OCIO is reformed following photolysis supporting the geminate recombination model presented above.

The OCIO ground-state recovery kinetics were determined through analysis of the temporal evolution in OCIO symmetric-stretch scattered intensity (Figure 3A). Comparison of initial depletion amplitude to that observed at later delays establishes that the geminate-recombination quantum yield in aqueous solution is ~ 0.80 , in excellent agreement with the transient-absorption studies.¹⁴⁻¹⁹ Inspection of Figure 3A demonstrates that recovery of the symmetric-stretch fundamental intensity is multi-exponential. Consistent with this observation, the data were best modeled by a sum of three exponentials convolved with the instrument response resulting in recovery time constants of 0.15 ± 0.1 ps (i.e., instrument-response limited given the 0.7-ps spectrometer), 9.2 ± 3.5 ps, and a fixed, long-time component

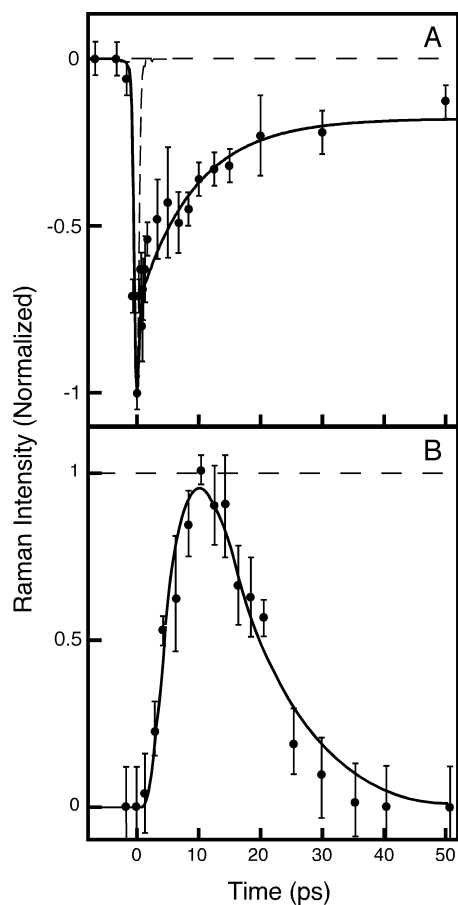

Figure 3. **A.** Intensity of the OCIO symmetric-stretch fundamental Stokes transition as a function of time. Best fit to the data by a sum of exponentials convolved with the instrument response (solid line) was obtained with time-constants (with normalized amplitude in parenthesis) of 0.15 ± 0.1 ps (0.65), 9.2 ± 3.5 ps (0.27), and 10000 ps representing the long-time offset in intensity (0.08).

B. Intensity of the OCIO symmetric stretch anti-Stokes fundamental transition as a function of time. Best fit to the data by a sum of two exponentials convolved with the instrument response (solid line) was obtained with an appearance time-constant (with normalized amplitude in parenthesis) of 5.2 ± 1.5 ps (0.5) and a decay time-constant of 9.2 ± 1.7 ps (0.5).

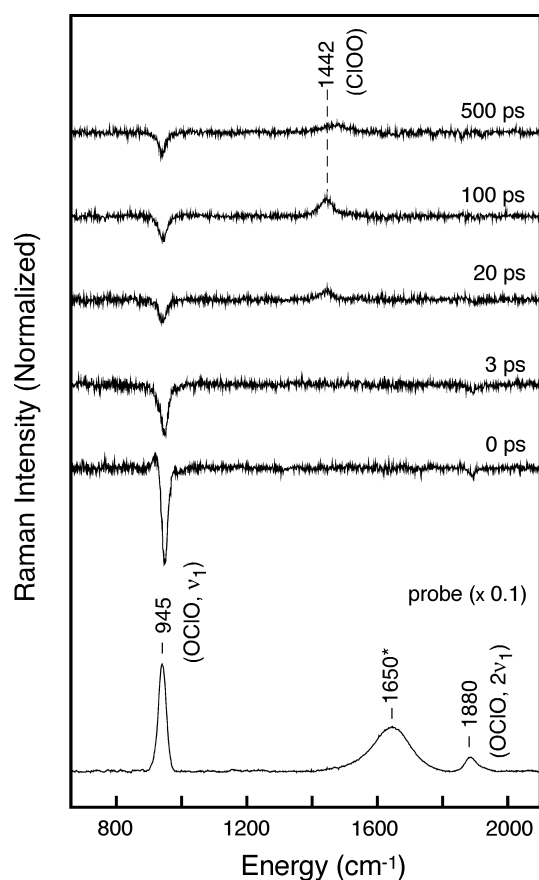

Figure 4. Time-resolved resonance Raman Stokes difference spectra of aqueous OCIO obtained with pump and probe wavelengths of 390 and 260 nm, respectively. The temporal delay between the pump and probe for a given spectrum is indicated. The probe only spectrum of aqueous OCIO (scaled by 0.1) is presented at the bottom of the figure. The peak marked with an asterisk in the probe-only spectrum is due to the solvent.

representing the persistent intensity depletion. The sub-picosecond and 9.2-ps time-constants are assigned to geminate recombination and intermolecular vibrational relaxation, respectively, as demonstrated below.

Given that geminate-recombination results in the reformation of ground-state OCIO, comparison of the ClO and O electronic energies relative to the ground-state of OCIO suggests that OCIO should be produced with considerable excess vibrational energy. This expectation is born out by the presence of substantial OCIO anti-Stokes intensity as shown in Figure 2B. At 6-ps delay, anti-Stokes intensity corresponding to the OCIO symmetric-stretch fundamental and overtone transitions is observed. This intensity initially increases with time, then decays at later delays due to vibrational relaxation. Figure 3B presents the integrated intensity of the symmetric-stretch fundamental anti-Stokes transition as a function of time. Best fit to these data by the sum of two exponentials convolved with the instrument

response resulted in an appearance of 5.2 ± 1.5 ps and decay time of 9.2 ± 1.7 . In addition, adequate reproduction of the experimental intensities could only be obtained through the addition of a 3-ps delay relative to zero time. The 9.2-ps anti-Stokes decay time is in exact agreement with the longer time-constant for Stokes scattering recovery demonstrating that this time constant corresponds to vibrational relaxation.²⁰

The observation of anti-Stokes intensity along the symmetric-stretch coordinate demonstrates that following geminate recombination, excess vibrational energy is eventually deposited along this coordinate. However, comparison of the Stokes and anti-Stokes kinetics demonstrates that the excess vibrational energy is initially localized along the asymmetric-stretch. Specifically, the subpicosecond recovery in symmetric-stretch depletion intensity observed in the Stokes data is not reflected by a similar, rapid appearance of anti-Stokes intensity. Theoretical analysis of the temperature dependence of the anti-Stokes cross sections demonstrates that the symmetric-stretch coordinate should carry significant anti-Stokes intensity, even at elevated temperatures. Therefore, the absence of intensity can not be assigned to depression of the anti-Stokes cross sections. The absence of anti-Stokes intensity along the symmetric stretch at early delays suggests that following geminate recombination, the excess energy excess is deposited along another coordinate, presumably the resonance Raman inactive asymmetric-stretch. The 5-ps anti-Stokes appearance time then provides a measure of intramolecular vibrational reorganization (i.e., distribution of vibrational energy throughout the normal modes) resulting in excess-energy deposition along the symmetric stretch. In summary, the TRRR studies at 390 nm have provided definitive evidence for geminate recombination of the primary photofragments resulting in the formation of ground-state OCIO, and that the intramolecular- and intermolecular-vibrational relaxation dynamics of OCIO occur on competitive timescales.

Our TRRR studies have also provided important insights into the mechanism of Cl formation following OCIO photoexcitation.²¹ It had been proposed that Cl formation occurs through the production and thermal decomposition of CIOO formed through OCIO photoisomerization. Although the results of femtosecond transient-absorption studies could be interpreted in terms of CIOO production and decay, direct evidence of the presence of this intermediate was desperately needed to confirm this hypothesis. Figure 4 presents time-resolved resonance Raman difference spectra obtained with actinic and probe wavelengths of 390 and 260 nm, respectively. Since the 260-nm probe is resonant with the strong electronic transition of CIOO, this wavelength provides the best opportunity to study the formation of this intermediate. The 0-ps difference spectrum (Figure 4) demonstrates negative intensity in transitions corresponding to OCIO consistent with ground-state depletion due to photolysis. Consistent with the studies outlined above, the extent of OCIO depletion decreases with an increase in delay time due to geminate recombination of

the primary photoproducts. It should be kept in mind when viewing Figure 4 that the OCIO symmetric-stretch fundamental Stokes scattering cross section is $<10^{-10} \text{ \AA}^2$ at this probe wavelength! Furthermore, the OCIO intensity at 0-ps delay represents only 10% depletion of the ground state. When compared to TRRR studies of olefinic systems where scattering cross sections are easily 10^3 larger²², it is clear that the recent developments in laser technology outlined above have dramatically extended the capabilities of TRRR spectrometers.

The TRRR data presented in Figure 4 demonstrate that CIOO is indeed a photoproduct of aqueous OCIO. Inspection of the 20-ps spectrum demonstrates the presence of positive intensity at 1442 cm^{-1} . Infrared studies of OCIO photochemistry in low-temperature matrixes have assigned transitions at 1441, 407, and 200 cm^{-1} to the presence of CIOO.²³⁻²⁵ Given this, the observation of intensity at 1442 cm^{-1} provides conclusive evidence for CIOO formation. The temporal evolution in CIOO scattered intensity (Figure 5) was best modeled by a sum of two exponentials convolved with the instrument

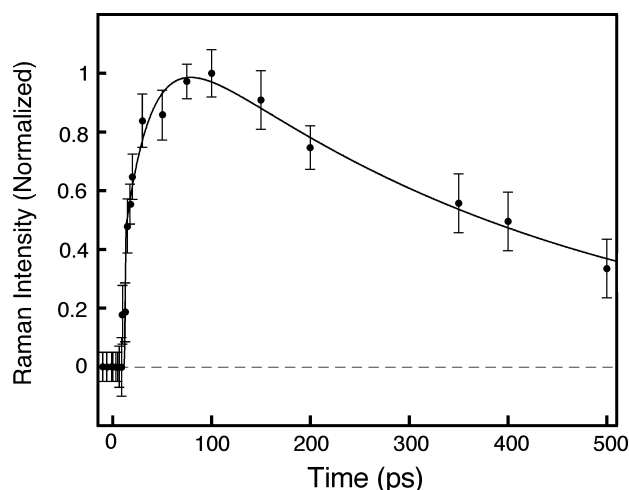

Figure 5. Intensity of the CIOO transition at 1442 cm^{-1} as a function of pump-probe delay. The data best fit a sum of two exponentials convolved with the instrument response resulting in appearance and decay time-constants of 27.9 ± 4.5 ps and 398 ± 50 ps, respectively. In addition, inclusion of a 12.7 ± 1.5 ps dwell relative to zero time was necessary to reproduce the data.

response resulting in an appearance and decay time-constants of 27.8 ± 4.5 ps and 398 ± 50 ps, respectively. In addition, a delay of 12.7 ± 1.5 ps was included in order to reproduce the absence of scattering at early times. The picosecond production of ClOO is markedly slower than the subpicosecond formation of ground-state OCIO suggesting that ClOO formation does not occur by geminate recombination. In contrast, the picosecond appearance time and 12.7 ps delay determined in the kinetic analysis suggests that ClOO is initially produced in the excited state. Under C_s symmetry, the lowest-energy excited-state of OCIO correlates with the ${}^2A'$ excited-state of ClOO and not the ${}^2A''$ ground state. Therefore, OCIO photoexcitation should result in the formation of excited-state ClOO. Internal conversion from the ${}^2A'$ surface on the picosecond timescale would result in the delayed appearance of ground-state ClOO. Internal conversion to the ground state will result in the production of vibrationally-hot ClOO, with vibrational relaxation most likely contributing to the ~ 30 -ps ClOO appearance time (Figure 5). Finally, the ~ 400 -ps ClOO decay time-constant is consistent with thermal dissociation resulting in the formation of Cl and O_2 . This conclusion is strengthened by comparison to the ~ 200 -ps Cl appearance time observed in the femtosecond transient-absorption studies.²⁶ It should be noted that femtosecond transient-absorption studies demonstrate that Cl is also produced on the ~ 5 ps timescale. It has been suggested that the "prompt" production of Cl is due to the dissociation of ClOO in the excited state consistent with ClOO being the precursor to Cl formation.

Conclusions and Prospects

The future looks extremely promising for the application of time-resolved resonance Raman to problems in environmental chemistry. The wealth of information provided by this technique allows for the detailed investigation of many environmental-relevant photochemical processes. The studies described here have demonstrated that geminate recombination of the ClO and O primary photofragments resulting in the reformation of OCIO is a central component of the reaction dynamics of OCIO in condensed environments. It should be noted that similar behavior has been observed for dichlorine monoxide (ClOCl) indicating that primary photoproduct geminate recombination may be a general feature of halooxide reactivity in condensed environments.²⁷ We have also shown that the structural detail inherent in TRRR makes this technique an excellent complement to time-resolved absorption spectroscopy. Finally, the availability of frequency-agile, high-repetition-rate laser sources promises to expand the application of TRRR in many other areas of photochemistry.

Acknowledgments

I would like to acknowledge the vital contributions of my co-workers Sophia Hayes, Matthew Philpott, and Carseten Thomsen (Aarhus University, Denmark). The National Science Foundation is acknowledged for their support of this work through the CAREER program (CHE-9701717). Acknowledgment is also made to the donors of the Petroleum Research Fund, administered by the American Chemical Society.

References

1. Walker, G. C.; Hochstrasser, R. M. *Ultrafast Vibrational Spectroscopy: Methods, Theory and Applications*. In *Laser Techniques in Chemistry*; Myers, A. B., Rizzo, T. R., Eds.; John Wiley and Sons: New York, 1995; Vol. 23; pp 385-422.
2. Thompson, P. A.; Mathies, R. A. *Time-Resolved Resonance Raman in the Visible and Ultraviolet: Techniques and Applications*. In *Laser Techniques in Chemistry*; Myers, A. B., Rizzo, T. R., Eds.; John Wiley and Sons: New York, 1995; Vol. 23; pp 185-210.
3. Towrie, M.; Parker, A. W.; Shaikh, W.; Matousek, P. *Meas. Sci. and Tech.* **1998**, *9*, 816.
4. Uesugi, Y.; Mizutan, Y.; Kitagawa, T. *Rev. Sci. Inst.* **1997**, *68*, 4001.
5. Asaki, M. T.; Huang, C.-P.; Garvey, D.; Zhou, J. P.; Murnane, M. M.; Kapteyn, H. C. *Optics Lett.* **1993**, *18*, 977.
6. Pfeilsticker, K.; Blom, C. E.; Brandtjen, R.; Fischer, H.; Glatthor, N.; Grendel, A.; Bulde, T.; Hopfner, M.; Perner, D.; Piesch, C.; Platt, U.; Renger, W.; Sessler, J.; Wirth, M. *J. Geophys. Res.* **1997**, *102*, 10801.
7. Vaida, V.; Simon, J. D. *Science* **1995**, *268*, 1443.
8. Sessler, J.; Chipperfield, M. P.; Pyle, J. A.; Toumi, R. *Geophys. Res. Lett.* **1995**, *22*, 687.
9. Burkholder, J. B.; Talukdar, R. K.; Ravishankara, A. R. *Geophys. Res. Lett.* **1994**, *21*, 585.
10. Rowland, F. S. *Annu. Rev. Phys. Chem.* **1991**, *42*, 731.
11. Solomon, S.; Sanders, R. W.; Miller Jr., H. L. *J. Geophys. Res.* **1990**, *95*, 13807.
12. Chang, Y. J.; Simon, J. D. *J. Phys. Chem.* **1996**, *100*, 6406.

13. Dunn, R. C.; Flanders, B. N.; Simon, J. D. *J. Phys. Chem.* **1995**, *99*, 7360.
14. Thørgersen, J.; Jepsen, P. U.; Thomsen, C. L.; Poulsen, J. A.; Byberg, J. R.; Keiding, S. R. *J. Phys. Chem.* **1997**, *101*, 3317.
15. Poulsen, J. A.; Thomsen, C. L.; Keiding, S. R.; Thørgersen, J. *J. Chem. Phys.* **1998**, *108*, 8461.
16. Thørgersen, J.; Thomsen, C. L.; Poulsen, J. A.; Keiding, S. R. *J. Phys. Chem. A* **1998**, *102*, 4186.
17. Philpott, M. J.; Charalambous, S.; Reid, P. J. *Chem. Phys.* **1998**, *236*, 207.
18. Philpott, M. J.; Charalambous, S.; Reid, P. J. *Chem. Phys. Lett.* **1997**, *281*, 1.
19. Hayes, S. C.; Philpott, M. J.; Reid, P. J. *J. Chem. Phys.* **1998**, *109*, 2596.
20. Hayes, S. C.; Philpott, M. P.; Mayer, S. G.; Reid, P. J. *J. Phys. Chem. A* **1999**, *103*, 5534.
21. Thomsen, C. L.; Philpott, M. P.; Hayes, S. C.; Reid, P. J. *J. Chem. Phys.* **2000**, *112*, 505.
22. Reid, P. J.; Doig, S. J.; Wickham, S. D.; Mathies, R. A. *J. Am. Chem. Soc.* **1993**, *115*, 4754.
23. Mueller, H. S. P.; Willner, H. *J. Phys. Chem.* **1993**, *97*, 10589.
24. Rochkind, M. M.; Pimentel, G. C. *J. Chem. Phys.* **1967**, *46*, 4481.
25. Arkell, A.; Schwager, I. *J. Am. Chem. Soc.* **1967**, *89*, 5999.
26. Thomsen, C. L.; Reid, P. J.; Keiding, S. R. *J. Am. Chem. Soc.*, submitted for publication.
27. Esposito, A. P.; Reid, P. J.; Rousslang, K. W. *J. Photochem. and Photobiol. A, Chemistry* **1999**, *129*, 9.

About the Author

Philip J. Reid received his Ph.D. from the University of California, Berkeley. He is the recipient of a Dreyfus New-Faculty Award, a Cottrell Fellowship of the Research Corporation, and an Alfred P. Sloan Fellowship. Dr. Reid may be contacted at the Department of Chemistry, University of Washington, Box 351700, Seattle, Washington 98195, email: preid@chem.washington.edu.

©Copyright 2000 by the Center for Photochemical Sciences
The Spectrum is a quarterly publication of the Center for
Photochemical Sciences, Bowling Green State University,
Bowling Green, OH 43403.
Phone 419-372-2033 Fax 419-372-0366
Email photochemical@listproc.bgsu.edu
WWW <http://www.bgsu.edu/departments/photochem/>

Executive Director: D. C. Neckers
Principal Faculty: G. S. Bullerjahn, J. R. Cable,
F. N. Castellano, M. E. Geusz,
D. C. Neckers, M. Y. Ogawa,
V. V. Popik, M. A. J. Rodgers,
D. L. Snavely

The Spectrum Editor: Pat Green
Production Editor: Alita Frater

COPYRIGHT PERMISSION

A person may make a single copy of any or all articles in this issue for personal use. Copying beyond that permitted by the U.S. Copyright law is allowed provided that the appropriate per copy fee is paid through the Copyright Clearance Center, Inc., 27 Congress St., Salem, MA 01970. For reprint permission, please write to the Center for Photochemical Sciences.

EDITORIAL POLICY

The Spectrum reserves the right to review and edit all submissions. The Spectrum is not responsible for contents of articles.

Articles submitted to The Spectrum will appear at the discretion of the editorial staff as space is available.

Imaging with Polymers, How It All Began

Arnost Reiser, Institute of Imaging Sciences, Polytechnic University

It all began with bichromated gelatin. Fox Talbot discovered it in the late 1840s and took out an early British patent (British 565, 1852) on the material.¹ Originally, bichromated gelatin was meant to serve graphic artists, but it soon became the preferred material for photolithography. In this role it has served for over 100 years. It was an ideal medium, it was cheap, available everywhere, it was forgiving in exposure and the plates were developable in warm water. All one needed was a good recipe. Mike Bruno provided recipes for the printing trade as late as 1954.² Bichromated gelatin had only one drawback: the plates had to be coated freshly every morning. It was not possible to pre-coat plates one day and use them even a few days later.

You can imagine that there was a great desire in the industry for so-called “pre-sensitized” plates which would relieve the print shop of the disagreeable chore of plate coating, drying etc. Several laboratories were looking for a way of producing stable pre-sensitized plates, and a small effort of this kind was going on at Eastman Kodak in Rochester. It was known by then that bichromated gelatin functioned on the basis of crosslink formation between gelatin chains.³ Louis Minsk, the young chemist charged with developing pre-sensitized plates at Eastman Kodak, was desperately searching the literature for inspiration. In those days the only textbook was “Organic Photochemistry” by Schoenberg. When Hitler came to power, Schoenberg left Germany and at some point found himself in Egypt, at the University of Cairo. There were only modest facilities in Cairo, but one commodity was in abundant supply: sunlight, and so Dr. Schoenberg started to work in photochemistry and wrote a book about it. The last chapter deals with the photochemistry of solids, and there is only a single reaction in this section: the dimerization of cinnamic acid. This gave Louis Minsk an idea; he thought of using cinnamoyl groups to crosslink vinyl polymers. Early experiments seemed promising, but Kodak’s management was not enthusiastic and the project floundered. Then, interest was refocused on this area by an unforeseen incident: the transistor had been invented at Bell Laboratories.

In the early development of solid state devices, Bell Labs tried to use bichromated gelatin as a lithographic medium to prepare small operational pattern on the surface of germanium and of silicon crystals. However, the gelatin pattern formed on these occasions could not withstand the etching solutions which had to be applied to the work pieces. It became clear that a completely hydrophobic imaging material was required. Dr. Shockley, who was in charge of these developments at Bell Labs, called Kenneth Mees, the head of Eastman Kodak research, and that is how Louis Minsk became embroiled in semiconductor technology. He soon produced a viable embodiment of the basic idea: the first synthetic photopolymer, poly(vinylcinnamate).⁴

At Bell Labs poly(vinylcinnamate) was an instant success. It produced a clear, crisp pattern and it was totally hydrophobic and untouched by the etchant. Eastman Kodak put it on the market under the name “Kodak Photo Resist” (KPR). Initially everybody was happy with KPR, but when Bell Labs, and later Fairchild, put together small production lines, the manufacturing yield of these lines was low, and we had our first customer complaint.

Eastman Kodak shunted the complaint to Kodak Limited in England where it came onto the desk of Martin Hopher. Hopher had grown up in the printing business. During the war he had followed the front line in an open truck and had printed maps for the troupes. He was now the head of Graphic Arts at Kodak and he soon diagnosed the problem: insufficient adhesion of KPR to the silicon substrate. To remedy this he tried to replace the brittle vinyl polymer with a rubbery material, but of course, the rubber needed to be made light-sensitive. Martin discussed this with his lunch partner, Hans Wagner, one of our best organic chemists. Hans had been reading papers by a Professor Horner in Mainz who managed to graft azides to hydrocarbons. Hans thought that if one mixed bis-azides into the rubber and exposed the mixture to UV radiation, the two azides might graft onto different chains and crosslink them. The idea worked almost immediately and led to the development of the highly successful “Kodak Thin Film Resist” (KTFR).⁵ KTFR became the preferred patterning material of the semiconductor device industry from 1959 until 1972.

What happened in 1972? The line width on the integrated circuits had shrunk at this point to 2 μm , and the rubber-based KTRF was no longer able to resolve these features. Within a few months the whole industry switched from KTRF to the Kalle positive Novolak-Diazoquinone resist, and Kodak lost the whole market. I was heavily involved in KTRF, and when the Kalle resist trounced us I bought a bottle of Kalle Kopierlack and tried it. It worked perfectly, but how did it do it? Nobody knew, so I started some research to find out. Quite reasonably, management was not pleased. "Do something useful" they said. It took almost 20 years and a move to Brooklyn to bring me back to the problem of Novolak resists.

I do not blame the Kodak management for their lack of enthusiasm about resists in general. With a market size of less than \$100,000, photoresists for microlithography were barely visible on the Eastman Kodak horizon. The materials got more attention when they became the basis of pre-sensitized litho plates. With this step the crosslinking resists proved themselves to be full substitutes for bichromated gelatin, and it had become clear that synthetic polymers could be used to produce high quality images. This realization came earlier in some quarters, later in others, and it gave rise to two diverging lines of development.

Lithography had been taken care of by crosslinking resists, but the primary and senior printing method, letterpress, was still linked to the old Gutenberg technology, except that wood blocks had given way to metal type, and that linotype (line casting) had replaced the manipulation of individual letters. Why should crosslinking resists not be used for letterpress? The main reason was that crosslinking resists could only be coated as thin films while letterpress required high profile letters to allow for the excess ink to flow into the valleys. High profile? That might be achieved by photoinitiated polymerization.

Photoinitiated polymerization had been in the sights of several academic departments in the United Kingdom. Burnett and Melville⁶ at Aberdeen had managed to initiate polymerization by UV irradiation (1947). Bamford and Dewar⁷ at Manchester had sensitized photo-initiated polymerization with VAT dyes (1949). Experiments were reported from other universities, but none were aimed at a printing application. However, enough information was unearthed to make an approach to photopolymer plates imaginable. Louis Plambeck of DuPont started to think on these lines sometime in 1948, but many obstacles had to be overcome before the basic idea was transformed into a viable letterpress plate. The sketch attached to US patent 2,760,863 issued in 1956 gives some idea of the complexity of the final design.⁸ In October 1986 Louis Plambeck visited Polytechnic, and he gave a riveting account of the birth of the Dycril Plate. As he was describing the successive stages of development and their problems he said, with a sigh, "...of course the most difficult part was to sell the idea to management." He was only half joking. DuPont of course had not been the only people to realize the possibilities of photoinitiated polymerization. Similar approaches were pursued at Time Incorporated⁹ (1956) and at BASF¹⁰ (1958). The new polymer plates transformed the whole global landscape of the printing industry. Within a few years they replaced metal type almost completely and created a huge photochemical business.

I would like to mention here another effort that intersected with the work at Dupont. In several laboratories there had been informal discussions about the possibility of a polymer photography. Polymerization seemed to provide the necessary amplification mechanism required for a reasonably sensitive photographic system. There was, however, another problem: most systems had to be irradiated with UV and were almost insensitive to visible light. Oster and Mark¹¹ of the Polytechnic Institute of Brooklyn discussed the problem in the Journal of the Optical Society of America. A year later (1954) Gerald Oster disclosed a system of very high sensitivity.¹²

Then, out of the blue, Oster got a call from Wilmington, would he like to visit DuPont? When he arrived he was asked point blank how much money he wanted to assign his forthcoming patent to DuPont? Oster thought they were joking. At the time he and Gisela were trying to buy a house on Eleventh Street in Greenwich Village, and to continue in the joke Gerald named the purchase price of that house. To his amazement DuPont agreed on the spot. And so Oster traveled back to New York and bought the house. And a very nice house it was. I have been there for several wonderful parties. The Oster patent in itself was not worth much, but it did get in the way of the Plambeck patent that DuPont was preparing, and that made it valuable. There is a lesson somewhere in this story, but I am not sure where.

The story of photopolymers has not ended, in fact imaging with photopolymers is now a huge multi-billion dollar business. Negative-working lithoplates are based on crosslinking resists of the poly(vinylcinnamate) type, positive-working lithoplates are based on the Novolak-Diazoquinone system, letterpress is dominated by photo-initiated polymerization, and photo-resists of one type or another are indispensable ingredients in the manufacture of integrated circuits (chips). I would really love to know what comes next.

References

1. Br. Patent, 565, 1852.
2. Joergensen, J.G.; Beuno, M.H. In *The Sensitivity of Bichromated Coatings*; Lithographic Technical Foundation: New York, 1954.
3. Biltz, M.; Eggert, J. *Wiss. Veroeff. AGFA* **1928**, 3, 294.
4. Minsk, L. M.; VanDeusen, W. P. U.S. Patent 2,690,966, 1948.
5. Hepher, M.; Wagner, H. M. Br. Patent 762,985, 1954.
6. Burnett, G. M.; Melville, H. W. *Proc. Roy. Soc. A* **1947**, 189, 456-507.
7. Bamford, C. H.; Dewar, M. J. S. *Nature* **1949**, 163, 214.
8. Plambeck, Jr., L. U.S. Patent 2,760,863, 1956.
9. Leekly, R. M.; Soerensen, R. L. (Yime Inc.). German Patent, 1956.
10. Hoerner, W.; Olsen, B. (BASF). Belgian Patent, 1958.
11. Oster, G.; Mark H. M. *J. Opt. Soc. Am.* **1953**, 43283.
12. Oster, G. *Nature* **1954**, 173, 300.

About the Author

Arnost Reiser received his Ph.D. from Prague Technical University where he later became head of the Department of Physical Chemistry. In 1960 he moved with his family to England where he worked for Kodak Ltd. In 1982 he became director of the Institute of Imaging Sciences at the Polytechnic University in Brooklyn, New York. He has co-authored the official Czech Textbook of Physical Chemistry, and has written a book about photoresists. The National Council of Great Britain awarded him a D. Sc. In addition, he received the Henderson Medal of the Royal Photographic Society and the Heyrovsky medal of the Academy of Sciences of the Czech Republic. Prof. Reiser may be contacted at the Institute of Imaging Sciences, Polytechnic University, Brooklyn, New York 11201, email: areiser@duke.poly.edu.

The Spectrum on the World-Wide Web

The Spectrum is available on the Center's Web site: <http://www.bgsu.edu/departments/photochem/>. You can access via Acrobat Reader. There are instructions for downloading a free copy of Acrobat Reader from the Adobe Web site.

If you plan to access *The Spectrum* electronically, please send an e-mail to: photochemical@listproc.bgsu.edu. We will remove you from our paper mailing list. Please browse our Web site for up-to-date information about the Center and its programs.

Carotenoids – Free Radical Interactions

R. Edge and T. G. Truscott

School of Chemistry and Physics, Lennard-Jones Laboratories, Keele University

Introduction

The C_{40} carotenoids, and their oxygenated derivatives (xanthophylls) are built from eight isoprene units (Figure 1).

The central unit of the C_{40} structure consists of 22 carbon atoms and contains 9 double bonds and 4 side chain methyl groups. The end groups may or may not be cyclized and are given a Greek letter name as shown in Figure 2.

Although the numbering system shown in Figure 2 provides a means of naming carotenoids, the most important carotenoids have well-known trivial names which are typically used. For example, β -carotene is the trivial name for the orange pigment in carrots (it is the most widely recognized carotenoid, generally considered to be the

“parent” carotenoid) and lycopene is the red pigment in tomatoes. All carotenoid derivatives which contain oxygen functions are collectively known as xanthophylls. They can contain many oxygen functional groups including hydroxy-, methoxy-, aldehyde groups and carboxylic acids, usually on the 1-6 or 1'-6' ring positions.

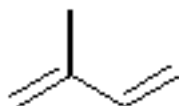

Figure 1. An isoprene unit.

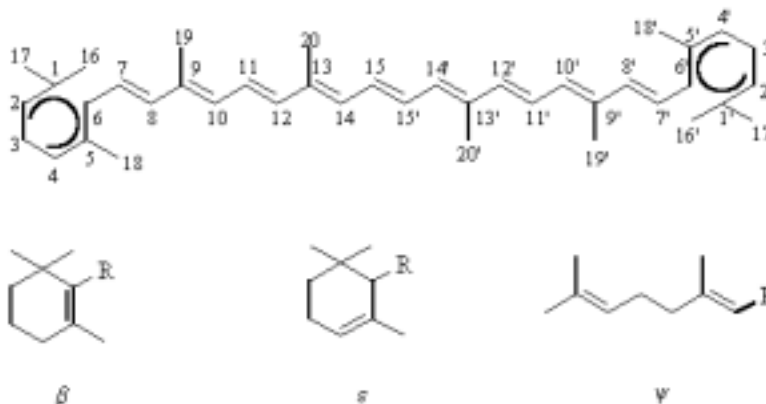

Figure 2. The numbering system of the stem name “carotene” and three of the seven prefixes which designate the end groups found in natural carotenoids.

Other structural features are

1. Carotenoids which have more than 40 carbon atoms are termed homo-carotenoids, while those with less are given the general name of apo-carotenoids if carbon atoms have been lost from the end of the molecule, and nor-carotenoids when they are removed from within the chain.
2. The term retro-carotenoid is used for structures in which the single and double bonds of the conjugated chain are shifted by one position.
3. Isomerism around the double bonds leads to a vast number of geometrical isomers, however, steric hindrance rules the majority of these out (e.g. 1056 forms of lycopene are theoretically possible but only 72 are sterically unhindered).
4. Many of the carotenoids found naturally are in their all-*trans* (all-*E*) forms. Carotenoids containing cyclic β -end groups favor the 6-*s-cis* conformation at the ring-chain junction, distorted by 40° from planarity to avoid steric hindrance of the C-5 methyl group and the C-8 hydrogen atom.

5. Chirality is also often seen in carotenoids, with the most common chiral center being the C-3 of the 3-Hydroxy- β -ring. This is illustrated well by zeaxanthin and mesozeaxanthin, which are in the 3R,3'R and 3R,3'S forms, respectively. Their structures, as well as the structures of all the other carotenoids discussed throughout this review, are given in Figure 3.

Carotenoids are abundant throughout the plant and animal kingdom although, in plants, chlorophyll often masks their presence. They are responsible for the coloration of many fruits, vegetables, birds, flowers and marine animals, such as, lycopene in tomatoes, canthaxanthin in flamingos and astaxanthin in salmon. Both plants and bacteria can synthesize carotenoids but mammals have to extract them from food, hence, they are not responsible for the coloration of any mammals, but, in humans, a diet rich in carotenoids causes a fake tan, with the skin turning orange, due to high subcutaneous carotenoid concentrations. Carotenoids are often associated with proteins. Examples of this type of complexation occur in photosynthetic pigment-protein complexes, and in lobsters, where the blue carotenoprotein is denatured upon cooking, liberating the red color free carotenoid, astaxanthin.

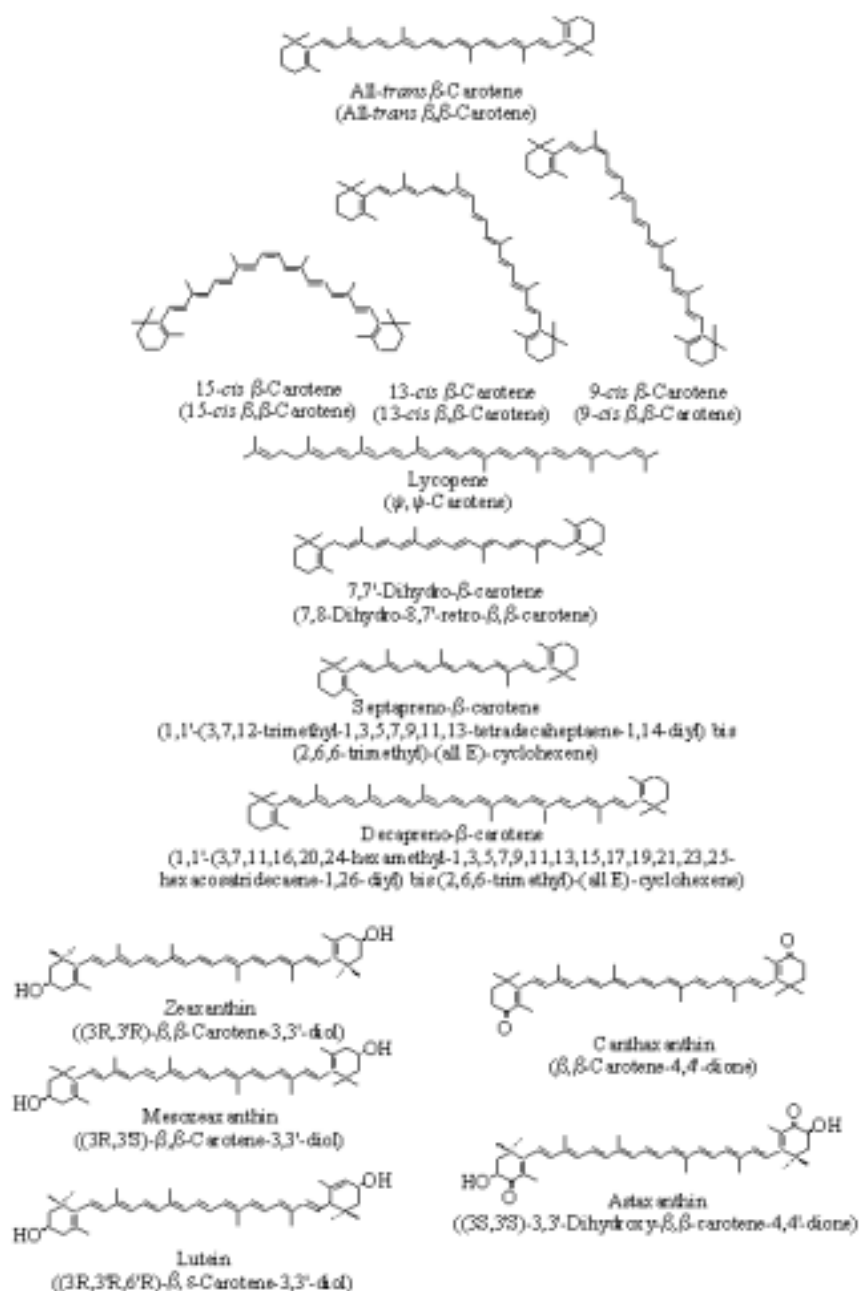

Figure 3. Typical carotenoid and xanthophyll structures.

Free carotenoids are relatively unstable molecules since they are sensitive to light and heat, causing cis-trans isomerization and degradation to smaller molecular weight fragments. However, *in vivo*, carotenoids, which are associated with proteins or other lipids, are more stable and not as susceptible to degradation.

Carotenoids have been studied for many years because:

1. They arise both in the reaction center and antenna complexes of photosynthetic systems.
2. They have wide-scale commercial use as food colorants, only about 4 mg of β -carotene is needed to color a ton of margarine. Carotenoids are used to color a wide range of foods and are fed to chickens to produce a deeper egg yolk coloration and to farmed salmon in order to achieve the color of wild salmon.
3. Carotenoids are also much studied because of their roles in medicine.

Erythropoietic Protoporphyrin (EPP)

Porphyric diseases are rare and usually hereditary. They are characterized by skin photosensitivity due to the presence of high levels of porphyrin. In EPP it is an excess of protoporphyrin, which causes the sensitivity. The build up of protoporphyrin is due to the enzyme ferrochelatase being defective and as such it is unable to insert iron into the protoporphyrin to make haem.

β -carotene has been shown to be useful in treating EPP, and is now widely used to increase tolerance to sunlight, with typical doses of 60 - 300 mg/day depending on the age of the patient. The treatment is not a cure for the disease. It merely reduces the acute skin photosensitivity. β -carotene is thought to assert its protective effect in a way analogous to photoprotection in photosynthesis, i.e. intercepting the triplet state of protoporphyrin and preventing the formation of singlet oxygen and/or quenching singlet oxygen directly.

Age-related Macular Degeneration (AMD) and Cataracts

The carotenoids which are in the macular (the so-called "yellow spot") of humans are zeaxanthin, mesozeaxanthin and lutein. Mesozeaxanthin, however, is not found in plasma, suggesting that it results from chemical reactions in the retina.

AMD is the major cause of blindness in people over 60 years of age in the developed world. It is a disease of the retina and so, unlike cataracts, cannot be cured, but treatment with carotenoids has been shown to afford some protection. One study using macaque monkeys found significant protection from β -carotene under normal conditions but found that the effects are less pronounced at high oxygen partial pressures.¹ A trial on 102 AMD sufferers found the degeneration of the macular either improved or arrested in 60% of the cases when a supplement of vitamins C and E, β -carotene and selenium was taken daily.² Additionally, in a study by Mares-Perlman et al. low serum levels of lycopene were related to the incidence of AMD.³

Cataract is a major cause of blindness throughout the world and it is associated more with smokers and those exposed to UV light, suggesting that it is caused by oxidative stress. The lens is constituted of 98% protein and it is lipid damage which is associated with cataract, causing opacity of the lens. There have been several studies in which high antioxidant status has been shown to be associated with low risk of cataract. One study using carotenoids has shown the incidence of cataract surgery to be about 30% lower in women with high β -carotene intakes, but also showed that consumption of foods containing high amounts of β -carotene did not significantly lower cataract incidence, whereas consumption of spinach, which is rich in zeaxanthin and lutein, did.

Heart Disease

High carotenoid intake may be able to protect against coronary heart disease, in particular, atherosclerosis, which is thought to be caused by oxidative damage. Measurements of carotenoids in blood plasma showed that in individuals from Toulouse, where there is a low incidence of coronary heart disease, the concentration of lutein and β -cryptoxanthin was twice as high as in people from Belfast, there was also 50% more α -carotene.⁴ In the Nurses Health Study,⁵ which monitored 121,000 nurses for eight years, it was found that there was a 22% reduction in the risk of coronary heart disease for those women in the top quintile for β -carotene consumption, compared with those in the bottom quintile.

Cancer

There have been many studies into the anticarcinogenic effects of carotenoids, especially since Peto et al.⁶ proposed that dietary β -carotene may be responsible for the reduced cancer risk associated with a diet rich in fruit and vegetables. For example, it has been proven that both α - and β -carotene suppress tumorigenesis in mice skin, with

α -carotene providing the greater protection.⁷ In the same study α -carotene reduced lung carcinogenesis, whereas β -carotene did not. A human nutrition intervention trial in Linxian, China, has shown supplementation with β -carotene, vitamin E, and selenium reduces cancer, especially in the stomach.⁸ Also, a case-control study in the US (with the intake of β -carotene and retinol calculated using dietary interviews) concluded that dietary β -carotene reduces the risk of lung cancer in nonsmokers, whereas retinol does not.⁹

However, there has been an upsurge of interest in the roles of the dietary carotenoids following reports that supplementation in the consumption of β -carotene may lead to deleterious effects in certain subpopulations such as heavy smokers.^{10,11} Linked to such observation, the pro-oxidant as well as antioxidant roles of the carotenoids are now much discussed. At the molecular level at least three processes are of importance to the roles of the dietary carotenoids:

1. The interaction with free radicals and other reactive oxygen species, and the reactivity of carotenoid radicals themselves.
2. The excited states, such as quenching of singlet oxygen ($^1\text{O}_2$) and porphyrin triplet states.
3. The up-regulation of cell-cell communication (gap junction potential-GJP).

The carotenoid quenching of excited states and role of carotenoids in GJP are not the subject of this review but they have been discussed elsewhere.¹²⁻¹⁴

Free Radical-Carotenoid Interactions

Since the quenching of free radicals by carotenoids is believed to contribute to their antioxidant properties and their ability to inhibit the onset of diseases, such reactions have been much studied.

Several distinct modes of reaction between free radicals and carotenoids have been reported. Generally the nature of the reaction depends on the type of radical rather than the carotenoid itself. Three types of reaction are

1. Electron transfer to yield carotenoid radical cations.
2. Hydrogen atom transfer to yield neutral carotenoid radicals.
3. Addition reactions to yield more than one complex radical, the nature of such species are not well characterized.

Electron Transfer to Generate Carotenoid Radical Cations

Many strongly oxidizing species, especially peroxy radicals, convert carotenoids (CarH) to their one-electron oxidized form, the cation radical (in many papers Car rather than CarH is used as the abbreviation for carotenoids):

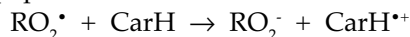

Amongst these oxy-radicals are the trichloromethyl peroxy radical, $\text{CCl}_3\text{O}_2^\bullet$, (a radical which causes hepatotoxicity), nitrogen dioxide, NO_2^\bullet , (a radical which arises from cigarette smoke and exhaust gases), thiyl sulphonyl (RSO_2^\bullet), aryl peroxy (ArO_2^\bullet), phenoxy radicals ($\text{C}_6\text{H}_5\text{O}^\bullet$), benzyl peroxy radicals ($\text{C}_6\text{H}_5\text{CH}_2\text{O}_2^\bullet$), the radical cation of α -tocopherol and the superoxide radical anion ($\text{O}_2^{\bullet-} + \text{CarH} + 2\text{H}^+ \rightarrow \text{H}_2\text{O}_2 + \text{CarH}^{+\bullet}$).

Electron transfer also generates the carotenoid radical cation in model photosynthetic systems. Thus, they arise by repair of the chlorophyll "special pair" [$(\text{chl})_2$, P_{680}] in photosystem II reaction centers, when the primary processes are blocked.¹⁵

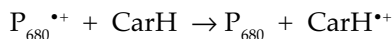

Carotenoid radical cations have also been observed following a two-step process, in carotenoid-porphyrin-quinone (C-P-Q) triad mimics of the reaction center.

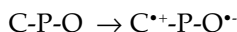

In addition, Skibsted and co-workers¹⁶⁻¹⁹ have shown that photoexcitation of a wide range of carotenoids in chloroform leads to the carotenoid radical cation, despite the extremely short lifetimes of the carotenoid excited states,²⁰ and Kispert and co-workers have demonstrated that carotenoid radical cations can be generated electrochemically.^{21,22}

The carotenoid radical cations are quite easy to detect because of their intense absorption in the near infrared region. These radical cation spectra were first characterized by the pulse radiolysis technique* more than twenty years ago,²³ and this technique has been much used in the study of the generation and properties of carotenoid radicals.

*A radiation chemistry technique in which the pulsed laser in flash photolysis is replaced by a pulse of fast (highly energetic) electrons which produce solvent radicals and, subsequently, one-electron oxidized and reduced solutes. The solution conditions are chosen to study whichever is of interest, e.g. N_2O is often used to convert the solvated electron, which is reducing, to hydroxyl radicals, which are oxidizing.

Reactivity of carotenoid radical cations

When an excited state is quenched by a carotenoid to generate the carotenoid triplet state (e.g. $^1\text{O}_2 + \text{CarH} \rightarrow ^3\text{O}_2 + ^3\text{CarH}$) the excess energy is dissipated as heat ($^3\text{CarH} \rightarrow \text{CarH}$). However, when a radical is quenched a new radical species is produced. If this new radical is reactive its formation may well have biological consequences. This may well be the situation for the carotenoid radical cations produced when a dietary carotenoid quenches an oxy-radical:

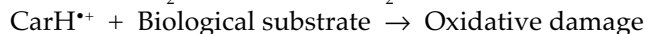
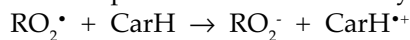

It is an interesting hypothesis that such $\text{CarH}^{*\bullet}$ reactivity may be associated with the possible deleterious effects of β -carotene dietary supplementation.

The efficiency of electron transfer reactions depend on the redox potentials involved. Several groups have obtained the relative reduction potentials of the radical cations of many dietary carotenoids. Edge et al.²⁴ determined the electron transfer rate constants, in benzene, between various pairs of dietary carotenoids, one of which was present as the radical cation (generated by pulse radiolysis):

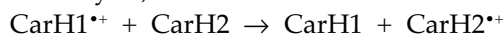

and suggested the order of relative reduction potentials, $E(\text{CarH}^{*\bullet}/\text{CarH})$ as:

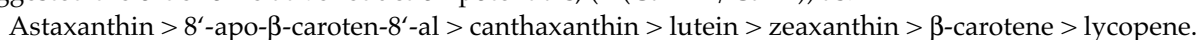

That is, lycopene is the strongest reducing agent (most easily oxidized) and the lycopene radical cation is the weakest oxidizing agent.

Rather similar results, obtained by less direct methods, have been reported by Miller et al.²⁵ and Mortensen et al.^{26,27} It may be noteworthy that Edge et al. showed that the radical cations of the macular carotenoids (lutein and zeaxanthin) are reduced by lycopene, e.g.:

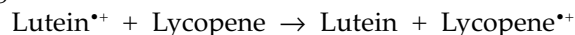

but not by β -carotene. It has been claimed that serum lycopene reduced the onset of AMD even though there is no lycopene in the eye, and such repair reactions of the retinal carotenoids may offer a molecular explanation (possibly a more likely explanation is, however, trace amounts of other materials associated with the lycopene supplementation).

While relative redox parameters are of interest, a key question is what is the absolute oxidizing strength of the carotenoid radical cations? I.e. what is the reduction potential $E(\text{CarH}^{*\bullet}/\text{CarH})$? Recently,²⁸ we have used pulse radiolysis to measure this parameter for five dietary carotenoids (β -carotene, lycopene, astaxanthin, zeaxanthin and canthaxanthin), by establishing the equilibrium, and measuring the equilibrium constant, between the radical cation of the amino acid tryptophan and the carotenoid:

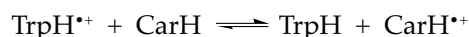

These were measured in aqueous micellar environments (Triton-X 100 and Triton-X 100/Triton-X 405 mixtures) as a function of pH. The values of E_0 so derived obtained for all five carotenoids are similar and lie in the range 1020 ± 40 mV. Comparing lycopene and β -carotene there is evidence that the reduction potential of the radical cation of lycopene is lower than that of β -carotene in agreement with the relative values for these two hydrocarbon carotenoids given above. However, the values for the xanthophylls are very similar to that of β -carotene which is different from the relative orders given above in non-polar environments. Possibly this is related to the terminal oxygenated substituent on the xanthophylls interacting with the aqueous environment at the micellar/water interface.

Interactions with amino acids and other biological substrates

The reduction potential of about 1000 mV we have obtained for the radical cations of the dietary carotenoids suggest that, once formed from reactive oxygen species, they will themselves be rather strong oxidizing agents. Figure 4 shows the reduction potentials of three amino acids as a function of pH. Clearly these predict that at physiological pH the dietary carotenoid radical cations should be able to oxidize both tyrosine and cysteine. Both of these reactions have been observed in an aqueous micellar system, e.g.:

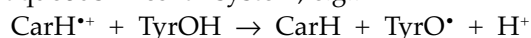

with the reaction with cysteine being more efficient. Since the reduction potentials of cysteine and tyrosine are very similar at pH 7 this suggests, at least in the micellar environments used for the study, other factors, as well as the redox driving force, are important. Recently, we have extended such studies to other molecules of biological interest and have observed reactivity of carotenoid radical cations with both uric acid and the polyphenol, ferrulic acid, to repair the carotenoids.

The inherent lifetimes of the carotenoid radical cations in a model of an *in vivo* environment are of importance in understanding their reactivity. In an attempt to gain information on this we have studied carotenoid radical cation lifetimes in three such environments; the neutral, positively and negatively charged micelles of Triton-X 100 (mixed Triton-X 100/405 micelles for lycopene), CTAB and SDS, respectively. These lifetimes were measured as a function of radiation dose. No effect of dose on the lifetime is observed, suggesting no contribution from second-order kinetic processes. However, in all cases, the decays are not single exponentials. All the carotenoid radical cations display kinetics that probably represent a distribution of exponential decays, and the radicals persist for milliseconds to seconds in the environments studied. As an example, making the simplifying assumption that the decay kinetics follow two exponentials, leads to lifetimes in TX-100 and CTAB of 7-16 ms and 2-6 ms for the short-lived component, with 40-100 ms and 10-30 ms for the longer-lived component, respectively. In SDS even longer lifetimes (up to 600 ms for canthaxanthin) arise from the biexponential approximation. If we assume three exponentials we obtain even longer lived components, lasting up to a few seconds.

These decays, taking place over long time scales, imply both the opportunity for the radical to reorientate itself within a membrane to react with a biological substrate leading to damage, or with ascorbic acid in the aqueous phase leading to reconversion of the carotenoid radical to its original form (i.e. repair of the carotenoid). The results, together with other work on the reduction of CarH^{•+} by vitamin C,²⁹ are consistent with the need for carotenoid dietary supplementation to be linked to vitamin C supplementation, especially for subpopulations with low vitamin C levels, such as smokers. This may offer insight into recent β -carotene epidemiological trials while supporting the beneficial role of carotenoids against oxy-radical induced disease under normal conditions. That is, radical cations of dietary carotenoids will be formed by the quenching of strong oxidizing species such as NO₂[•] (which arises from cigarette smoke). These carotenoid radical cations are sufficiently oxidizing and long-lived to oxidize protein components (and almost certainly other key biological targets) but such deleterious effects only arise if the repair of the radical cations by reducing agents, such as vitamin C, is reduced.

Another hypothesis which may arise from the redox potential measured for β -carotene concerns its role in photosynthetic reaction centers. Our results suggest that it is at least possible that the primary molecule which reduces P₆₈₀^{•+} is in fact β -carotene and that the radical cation of the carotenoid so formed is, in turn, reduced by tyrosine:

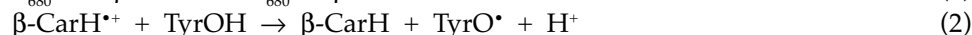

Whether or not $\beta\text{-CarH}^{\bullet+}$ would be detected in intact photosynthetic systems (it is detected in blocked systems¹⁵) simply depends on the steady-state concentrations of the $\beta\text{-CarH}^{\bullet+}$ and, hence, on the relative rates of processes (1) and (2). Where $\beta\text{-CarH}^{\bullet+}$ can be detected it may be that the geometry of the system has been sufficiently disturbed such that process (2) is reduced in efficiency.

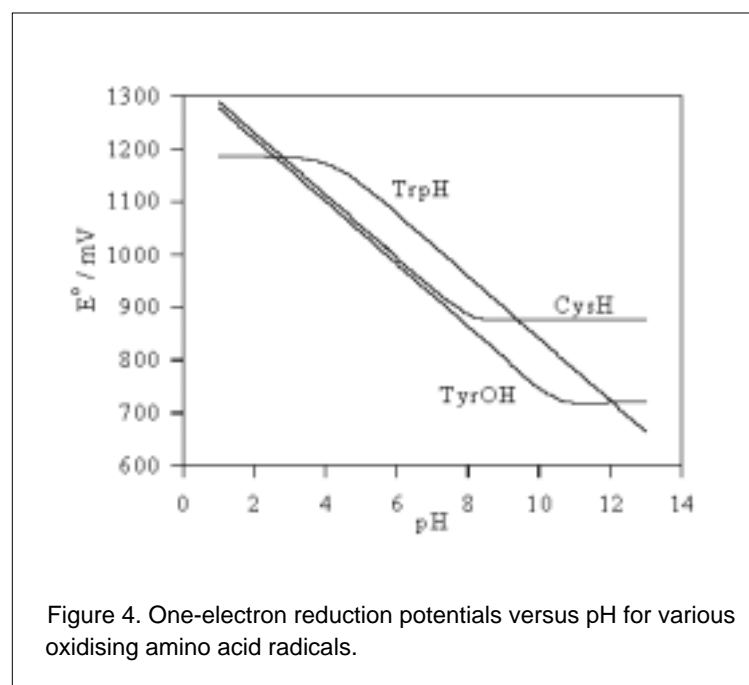

Figure 4. One-electron reduction potentials versus pH for various oxidising amino acid radicals.

Hydrogen Atom Transfer

We noted above that in the presence of chloroform carotenoids were oxidized by the CCl₃[•] radical,¹⁷ or, in the presence of oxygen, by the CCl₃O₂[•] peroxy radicals. In contrast, Skibsted and co-workers¹⁷ also noted that whilst carotenoids are also photobleached in carbon tetrachloride, no near infrared absorbing species could be detected. Possibly the neutral carotenoid radical is formed via hydrogen atom transfer:



However, the overall reaction is clearly more complex than this. More recently, Mortensen and Skibsted³⁰ have reported a study of the ability of β -carotene to scavenge three alkyl peroxy radicals, namely the cyclohexylperoxy, the tetrahydrofuranperoxy and the *t*-butanylperoxy radicals, by use of laser flash photolysis and steady-state techniques.

Only very slow reaction rates could be detected, corresponding to second-order rate constants of less than $10^6 \text{ M}^{-1}\text{s}^{-1}$. It was suggested that this slow reaction was due to either addition or hydrogen atom transfer reactions. Because it is difficult to characterize the neutral carotenoid radical, Car^\bullet (no distinctive strong absorption as is observed for the radical cations) there is little work available on such "simple" hydrogen atom transfer reactions.

Radical Addition Reactions

This is a rather confused topic because more than one "adduct" can be formed and the nature/characterization of these intermediates is not well established.

For the electron transfer reactions discussed above the situation is more complex than implied. Figure 5 shows typical transient spectra following the interaction of $\text{CCl}_3\text{O}_2^\bullet$ with lutein. As can be seen the radical cation ($\lambda_{\text{max}} = 900 \text{ nm}$) is not the only feature. Another species, absorbing at almost 80 nm shorter wavelength, is observed, and as this decays the radical cation is produced and similar transients arise with sulphonyl radicals. We have attempted to characterize this pre-radical cation species (by time-resolved resonance Raman spectroscopy³¹) but, to date, without success. Similar transient species have been reported by Skibsted and co-workers but not in the absence of oxygen. Thus, it seems that these precursors of carotenoid radical cations only arise with oxygen centered radicals. It has been suggested they are best regarded as "ion pairs".

Several other radical addition processes have been reported, thus with thiyl radicals^{32,33} (RS^\bullet) only addition processes were observed, and the complex kinetics seem to indicate that the addition complex spectra overlap that of the parent molecule.

The above results refer to fast reaction studies in which lasers or pulses of fast electrons were used to generate the initial radical. In steady-state studies followed by product analysis there is also evidence of radical addition processes. Thus, Liebler and McLure³⁴ have oxidized β -carotene with radicals resulting from the thermal decomposition of azo-bis-(2,4-dimethyl valero nitrile) (AN=NA) and have studied the structure of the adducts formed by Atmospheric Pressure Chemical Ionization mass spectrometry. In benzene the AN=NA thermally decomposes to 2A^\bullet (carbon-centered radicals, $(\text{CH}_3)_2\text{CHCH}_2\text{CCH}_3\text{CN}$) and N_2 and the A^\bullet radicals react in the presence of oxygen to yield peroxy (AOO^\bullet) and alkoxy (AO^\bullet) radicals. "Substitution" products formed by replacement of a carotenoid hydrogen by one radical, and addition products in which β -carotene and two radical fragments are linked, were detected. Certainly, the precise nature of the intermediates formed in such processes needs further study.

In a recent interesting paper³⁵ Liebler and co-workers here investigated the products of the reaction between β -carotene and cigarette smoke (both filtered and unfiltered). A major product was identified as 4-nitro- β -carotene (*cis* and *trans* isomers). Experiments in which β -carotene was incorporated into liposomes showed "modest" inhibition of lipid peroxidation. Other studies involved the possible interactions with lipid-soluble vitamin E and water-soluble vitamin C. The results, again, suggested at least some protection of these antioxidants by the presence of β -carotene.

Overall, there has been much interest in carotenoid-radical addition reactions since the early work Burton and Ingold³⁶ interpreted pro-oxidant effects at high oxygen concentrations in terms of such adducts. However, the intervening 16 years have not allowed the unraveling of the nature of the carotenoid-radical addition products.

Overall, there has been much interest in carotenoid-radical addition reactions since the early work Burton and Ingold³⁶ interpreted pro-oxidant effects at high oxygen concentrations in terms of such adducts. However, the intervening 16 years have not allowed the unraveling of the nature of the carotenoid-radical addition products.

Conclusions

Carotenoids react with free radicals by several different mechanisms depending on the nature of the free radical and more or less independent of the structure of the carotenoid involved. With strongly oxidizing radicals the carotenoid radical cation is generated and many of the important properties of such carotenoid radicals, including the reduction potentials, are now established. These can be used

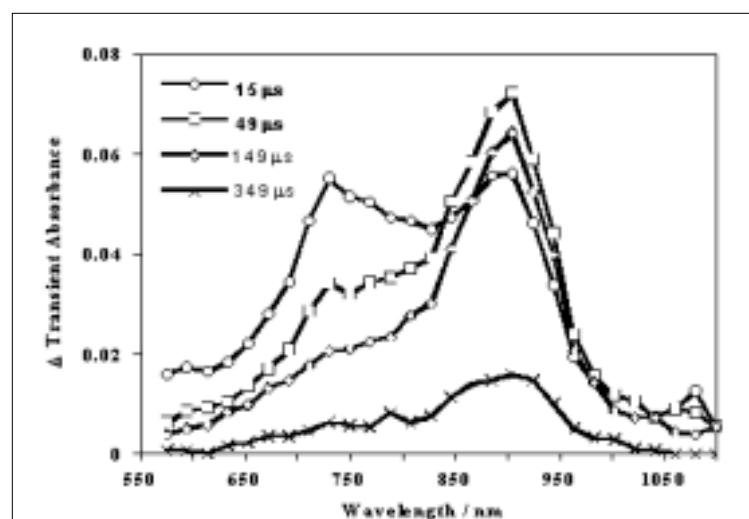

Figure 5. Spectra at various times after pulse radiolysis of 10^{-5} M lutein in aqueous air-saturated 2% Triton-X 100 containing 2 M 2-propanol, 1 M acetone, $5 \times 10^{-2} \text{ M}$ CCl_4 and 10^{-3} M phosphate buffer, pH 7. Pulse dose 10 Gy.

to hypothesize deleterious processes in man due to the strong oxidizing properties and rather long lifetimes of carotenoid radical cations and also to hypothesize that such deleterious processes are avoided by repair mechanisms with reducing agents such as vitamin C but that they may not be sufficiently efficient in subpopulations such as smokers.

Much less is understood about the nature of the addition reactions between dietary carotenoids and free radicals despite their obvious relevance to the biological situation.

Acknowledgments

We thank Hoffmann-la Roche (Basle) for support and for the supply of many carotenoids. We also thank Marc Burke, Ted Land and Dave McGarvey, for their collaboration.

References

1. Ham, W. T.; Mueller, H. A.; Ruffolo, J. J.; Millen, J. E.; Cleary, S. F.; Guerry, R. K.; Guerry, D. Basic mechanisms underlying the production of photochemical lesions in the mammalian retina. *Curr. Eye. Res.* **1984**, *3*, 165-174.
2. Cray, E. J. Antioxidant treatment of macular degeneration of the aging and macular edema in diabetic retinopathy. *South. Med. J.* **1987**, *80*, 38.
3. Mares-Perlman, J. A.; Brady, W. E.; Klein, R.; Klein, B. E. K.; Bowen, P.; Stacewicz-Sapuntzakis, M.; Palta, M. Serum antioxidants and age-related macular degeneration in a population-based case-control study. *Arch. Ophthalmol.* **1995**, *113*, 1518-1523.
4. Howard, A. N.; Williams, N. R.; Palmer, C. R.; Cambou, J. P.; Evans, A. E.; Foote, J. W.; Marques-Vidal, P.; McCrum, E. E.; Ruidavets, J. B.; Nigdikar, S. V.; Rajput-Williams, J.; Thurnham, D. I. Do hydroxy-carotenoids prevent coronary heart disease? A comparison between Belfast and Toulouse. *Int. J. Vit. Nutr. Res.* **1996**, *66*, 113.
5. Manson, J. E.; Stampfer, M. J.; Willet, W. C.; Colditz, G. A.; Rosner, B.; Speizer, F. E.; Hennekens, C. H. A prospective study of antioxidants vitamins and incidence of coronary heart disease in women. *Circulation* **1991**, *84*, 2168.
6. Peto, R.; Doll, R.; Buckley, J. D.; Sporn, M. B. Can dietary beta-carotene materially reduce human cancer rates? *Nature* **1981**, *290*, 201-208.
7. Nishino, H. Cancer chemoprevention by natural carotenoids and their related compounds. *J. Cell. Biochem.* **1995**, *Supp. 22*, 231-235.
8. Blot, W. J.; Li, J.-Y.; Taylor, P. R.; Guo, W.; Dawsey, S.; Wang, G.-Q.; Yang, C. S.; Zheng, S.-F.; Gail, M.; Li, G.-Y.; Yu, Y.; Liu, B.; Tangrea, J.; Sun, Y.; Liu, F.; Fraumeni, J. F. J.; Zhang, Y.-H.; Li, B. Nutrition intervention trials in Linxian, China: Supplementation with specific vitamin/mineral combinations, cancer incidence, and disease-specific mortality in the general population. *J. Natl. Can. Inst.* **1993**, *85*, 1483-1491.
9. Mayne, S. T.; Janerich, D. T.; Greenwald, P.; Chorost, S.; Tucci, C.; Zaman, M. B.; Melamed, M. R.; Kiely, M.; McKneally, M. F. Dietary β -carotene and lung cancer risk in U.S. nonsmokers. *J. Natl. Can. Inst.* **1994**, *86*, 33-38.
10. Omenn, G. S.; Goodman, G. E.; Thornquist, M. D.; Balmes, J.; Cullen, M. R.; Glass, A.; Keogh, J. P.; Meyskens, F. L.; Valanis, B.; Williams, J. H.; Barnhart, S.; Hammar, S. Effects of a combination of beta carotene and vitamin A on lung cancer and cardiovascular disease. *New Eng. J. Med.* **1996**, *334*, 1050-1055.
11. Peterson, K. Natural cancer prevention trial halted. *Science* **1996**, *271*, 441.
12. Edge, R.; McGarvey, D. J.; Truscott, T. G. The carotenoids as antioxidants - a review. *J. Photochem. Photobiol. B: Biol.* **1997**, *41*, 189-200.
13. Bertram, J. S. The chemoprevention of cancer by dietary carotenoids: studies in mouse and human cells. *Pure Appl. Chem.* **1994**, *88*, 1025-1032.
14. Stahl, W.; Nicolai, S.; Briviba, K.; Hanusch, M.; Broszeit, G.; Peters, M.; Martin, H. D.; Sies, H. Biological activities of natural and synthetic carotenoids: Induction of gap junctional communication and singlet oxygen quenching. *Carcinogenesis* **1996**, *18*, 89-92.
15. Telfer, A.; Dhami, S.; Bishop, S. M.; Phillips, D.; Barber, J. β -Carotene quenches singlet oxygen formed in isolated photosystem II reaction centers. *Biochem.* **1994**, *33*, 14469-14474.
16. Haila, K. M.; Nielsen, B. R.; Heinonen, M. I.; Skibsted, L. H. Carotenoid reaction with free radicals in acetone and toluene at different oxygen partial pressures. An ESR spin-trapping study of structure-activity relationships. *Lebensm. Unters Forsch.* **1997**, *204*, 81-87.
17. Mortensen, A.; Skibsted, L. H. Kinetics of photobleaching of β -carotene in chloroform and formation of transient carotenoid species absorbing in the near infra-red. *Free Rad. Res.* **1996**, *25*, 355-368.

18. Mortensen, A.; Skibsted, L. H. Kinetics of parallel electron transfer from β -carotene to phenoxyl radical and adduct formation between phenoxyl radical and β -carotene. *Free Rad. Res.* **1996**, *25*, 515-523.
19. Mortensen, A.; Skibsted, L. H. Formation of transient free radical carotenoid species. *Abstract, 11th Int. Symp. on Carotenoids, Lieden 1996*, 68.
20. Shreve, A. P.; Trautman, J. K.; Owens, T. G.; Albrecht, A. C. Determination of the S_2 lifetime of β -carotene. *Chem. Phys. Lett.* **1991**, *178*, 89-96.
21. Jeevarajan, J. A.; Wei, C. C.; Jeevarajan, A. S.; Kispert, L. D. Optical absorption spectra of dications of carotenoids. *J. Phys. Chem.* **1996**, *100*, 5637-5641.
22. Jeevarajan, J. A.; Wei, C. C.; Kispert, L. D. Geometrical isomerization of carotenoids in dichloromethane. *J. Chem. Soc., Perkin Trans. 2* **1994**, 861-869.
23. Dawe, E. A.; Land, E. J. Radical ions derived from photosynthetic polyenes. *J. Chem. Soc., Farad. Trans. I* **1975**, *71*, 2162-2169.
24. Edge, R.; Land, E. J.; McGarvey, D. J.; Mulroy, L.; Truscott, T. G. Relative ease of electron transfer of carotenoid radical cations and the interactions of carotenoids with the vitamin E radical cation. *J. Am. Chem. Soc.* **1998**, *120*, 4087-4090.
25. Miller, N. J.; Sampson, J.; Candeias, L. P.; Bramley, P. M.; Rice-Evans, C. A. Antioxidant activities of carotenes and xanthophylls. *FEBS Lett.* **1996**, *384*, 240-242.
26. Mortensen, A.; Skibsted, L. H. Relative stability of carotenoid radical cations and homologue tocopheroxyl radicals. A real time kinetic study of antioxidant hierarchy. *FEBS Lett.* **1997**, *417*, 261-266.
27. Mortensen, A.; Skibsted, L. H.; Sampson, J.; Rice-Evans, C.; Everett, S. A. Comparative mechanisms and rates of free radical scavenging by carotenoid antioxidants. *FEBS Lett.* **1997**, *418*, 91-97.
28. Edge, R.; Land, E. J.; McGarvey, D. J.; Burke, M.; Truscott, T. G. The reduction potential of the β -carotene^{•+}/ β -carotene couple in an aqueous micro-heterogeneous environment. *FEBS Lett.* **2000**, in press.
29. Edge, R.; Truscott, T. G. Prooxidant and antioxidant reaction mechanisms of carotene and radical interactions with vitamins E and C. *Nutr.* **1997**, *13*, 992-994.
30. Mortensen, A.; Skibsted, L. H. Reactivity of β -carotene towards peroxy radicals studied by laser flash photolysis and steady-state photolysis. *FEBS Lett.* **1998**, *426*, 392-396.
31. Tinkler, J. H.; Tavender, S. M.; Parker, A. W.; McGarvey, D. J.; Mulroy, L.; Truscott, T. G. Investigation of carotenoid radical cations and triplet states by laser flash photolysis and time-resolved resonance Raman spectroscopy: Observation of competitive energy and electron transfer. *J. Am. Chem. Soc.* **1996**, *118*, 1756-1761.
32. Everett, S. A.; Kundu, S. C.; Maddix, S.; Willson, R. L. Mechanisms of free-radical scavenging by the nutritional antioxidant β -carotene. *Biochem. Soc. Trans.* **1995**, *23*, 230S.
33. Everett, S. A.; Dennis, M.; Patel, K. B.; Maddix, S.; Kundu, S. C.; Willson, R. L. Scavenging of nitrogen dioxide, thiol, and sulphonyl free radicals by the nutritional antioxidant β -carotene. *J. Biol. Chem.* **1996**, *271*, 3988-3994.
34. Liebler, D. C.; McClure, T. D. Antioxidant reactions of β -carotene: Identification of carotenoid radical adducts. *Chem. Res. Toxicol.* **1996**, *9*, 8-11.
35. Baker, D. L.; Krol, E. S.; Jacobsen, N.; Liebler, D. C. Reactions of β -carotene with cigarette smoke oxidants. Identification of carotenoid oxidation products and evaluation of the prooxidant/antioxidant effect. *Chem. Res. Toxicol.* **1999**, *12*, 535-543.
36. Burton, G. W.; Ingold, K. U. β -carotene: An unusual type of lipid antioxidant. *Science* **1984**, *224*, 569-573.

About the Authors

George Truscott received his Ph.D. in 1961 and his D.Sc. in 1983 from the University of Wales. He is a Fellow of the Royal Society of Chemistry and a Fellow of the Royal Society of Edinburgh. After 17 years as Head of Department of Chemistry at Paisley University, he moved to Keele University as Head of the Department. Last year he became the Research Dean. He served as the first President of the European Society of Photobiology and Senior Editor of the *Journal of Photochemistry and Photobiology B: (Biology)* for five years. In 1993 he was the Lee Visiting Fellow in the Sciences at Christ Church College, Oxford. Dr. Truscott may be contacted at the School of Chemistry and Physics, Lennard-Jones Laboratories, Keele University, Staffordshire ST5 5BG, UK.

Ruth Edge graduated from Keele University in 1994 and was awarded her Ph.D. in 1998. She has worked at Keele since then in collaboration with Hoffmann-La Roche (Basle) until, in March of this year, she became a Marie Curie Fellow at CEA Saclay, France.